



COLLIER KALEIDOSCOPIES



# WINTER 2010

MAKERS OF HAND CRAFTED  
CONTEMPORARY KALEIDOSCOPIES  
SINCE 1989

WHOLESALE PRICE LIST

## HAND TURNED HARDWOODS

Lathe turned by hand. Mixed laminate  
hardwood and solid hardwood  
kaleidoscopes.

Hand polished sealed with wax and  
teak oil.

Magic Maker comes in 2 mirror  
mandala or 3 mirror infinite systems.  
Please specify at time of order.

### PEACEKEEPER

Turner reservoir  
2 mirror mandala  
Dichroic glass interior  
7 1/2" x 3 1/2"



### MAGIC MAKER

Non-turner reservoir  
2 and 3 mirror models  
Polymer clay interior  
7 3/4" x 2 7/8"



## TRIO (3-IN-1)

The TRIO contains a 3-mirror, a 2-mirror and a Vortex mirror  
system all inside 1 kaleidoscope. The exterior is wrapped in  
hand-dyed Batik fabric prints relating to nature. The interior has  
mixed polymer clay, shells & glass. Dimensions: 7.25" x 3.25"



Vortex

2-Mirror

3-Mirror



Eyecap detail showing  
3 viewing portals

TRIO's SOLD OUT-AVAILABLE JANUARY 2011



GALAXY



PALM



LEOPARD

## THEME SPIRITS



SNOWFLAKE  
Snowflake Simulator

SEASHORE  
Sea Life Interior

CHERRY BLOSSOM  
Nature Celebration

Same Specifications as Color Spirits below

## MUSIC BOX SCOPES



AMERICA  
Music: America  
the Beautiful  
Scent: Rose

ANGEL  
Classical Music  
Scent: None

## COLOR SPIRITS

Celebrating the spirit, emotion and  
inspiration of specific colors.

Each interior color theme matches the  
exterior body color. Charcoal and White  
have a variety of mixed colors pieces on the  
interior. Polymer clay, beads & glass.

Spec: 2 mirror Mandala. Turner End.  
Lens/dust protector. 8" x 2 7/8" dia.



Charcoal  
mixed color  
interior

White  
mixed color  
interior

Cherry

Aqua

Butterscotch

Orchid  
metallic pearl  
body

Lime

Orange

Yellow

## ORDERING INFORMATION AND NOTES

- All hand crafted art objects are suspended in side-lit, mineral oil reservoir with black background.
  - All mirrors are high optical quality first-surface mirrors.
  - All paints and plastic parts are lead free.
  - All kaleidoscopes are designed and hand crafted in the USA.
  - Delivery Lead Time is approximately 1 week after receipt of order (ARO) on all items except hardwoods. Hardwoods are 2-3 weeks leadtime ARO.
  - All prices are wholesale, FOB Portland Oregon USA. Shipping and handling are additional.
  - Optimal mastercase quantities for any combinations of Color Spirits, Theme Spirits and Music Box Scopes are 8, 16 or 25 units.
  - Phone in, fax in or e-mail orders to Michael Collier at the below contact information.
  - Credit cards are not accepted at this time.
- "Art objects tumble at random so mandala pattern will not repeat and each viewing is unique!"*

COLLIER KALEIDOSCOPIES, INC. 104 NE 66TH AVE. PORTLAND, OREGON 97213 USA  
T: +1 (503) 803-6534 F: +1 (503) 236-3383 MICHAEL@COLLIERKALEIDOSCOPIES.COM • WWW.COLLIERKALEIDOSCOPIES.COM





## KALEIDOSCOPE OVERVIEW HARDWOODS: PEACEKEEPER & MAGIC MAKER

Our laminated hardwoods kaleidoscopes have been hand-crafted on a wood lathe then sealed with teak oil and mineral wax. They stand upright, have a magnification lens and optical grade 'front-surface' mirrors, plus an oil reservoir for the art chamber. The images are created by using polymer clays and small pieces of fused dichroic glass. Solid wood pieces of Oak, Padouk, Black Walnut, Cherry, and occasionally some select burl make the hand selected pieces used to create these kaleidoscopes. We keep tiny knots, burl or other naturally occurring wood details. The exact laminations and wood cuts will vary slightly by artist choice.

### PEACEKEEPER

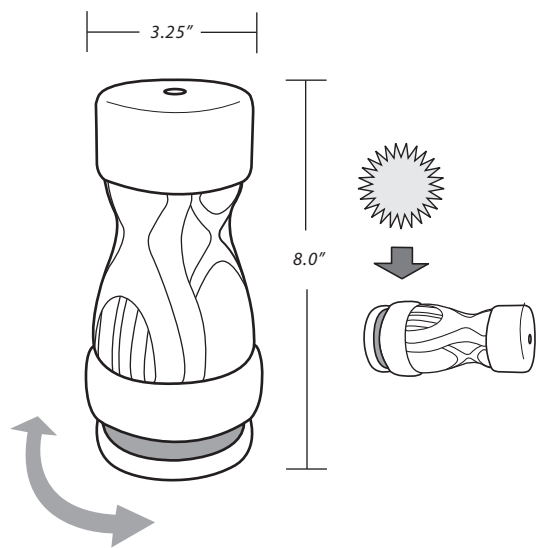

- Turner reservoir end cap.
- Hand crafted art objects, including fused dichroic glass are suspended in mineral oil. **Patterns do not repeat.**
- 2 Mirror / 6 point Mandala mirror system.



### MAGIC MAKER

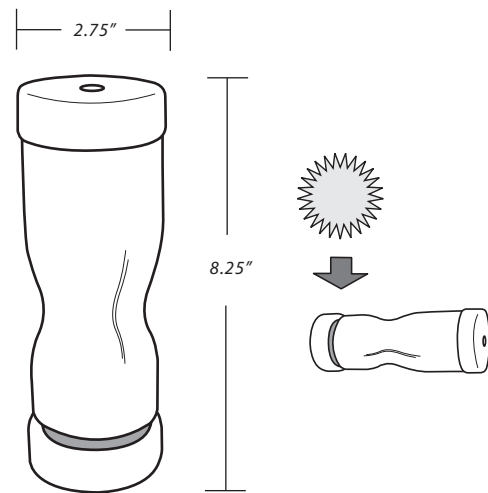

- Rotate entire scope when viewing.
- Hand crafted art objects and polymer clays are suspended in mineral oil. **Patterns do not repeat.**
- 2 mirror / 6 point Mandala mirror system.
- 3 mirror / infinite repeat mirror system are available upon request.

**These kaleidoscopes are 'side-lit'** which means bright light enters the object chamber from the side and illuminates the hand crafted art objects. This design technique creates a black background which can deliver more vibrant, crisper mandala patterns when compared to kaleidoscopes that you point directly at the light.

**DISPLAY VIEWING AREAS with overhead lights, near windows and especially sunlight, or bright lamp sources closely available will enhance viewing experiences.**





## KALEIDOSCOPE OVERVIEW TRIO (3 IN 1)

The TRIO is a visual exploration of color, pattern and light using 3 different mirror systems inside of 1 kaleidoscope. Each mirror system captures a specific form of visual symmetry and mood. The exterior body is wrapped in hand crafted Batik fabric. Our fabrics echo design elements found in nature through complex patterns and vibrant color. In one viewing, the hand crafted art objects will unfold beautiful imagery through 3 unique kaleidoscopes lenses. Pattern Styles available: Green GALAXY, Blue PALM and Black LEOPARD. Please see our website for detail interior and exterior pictures.

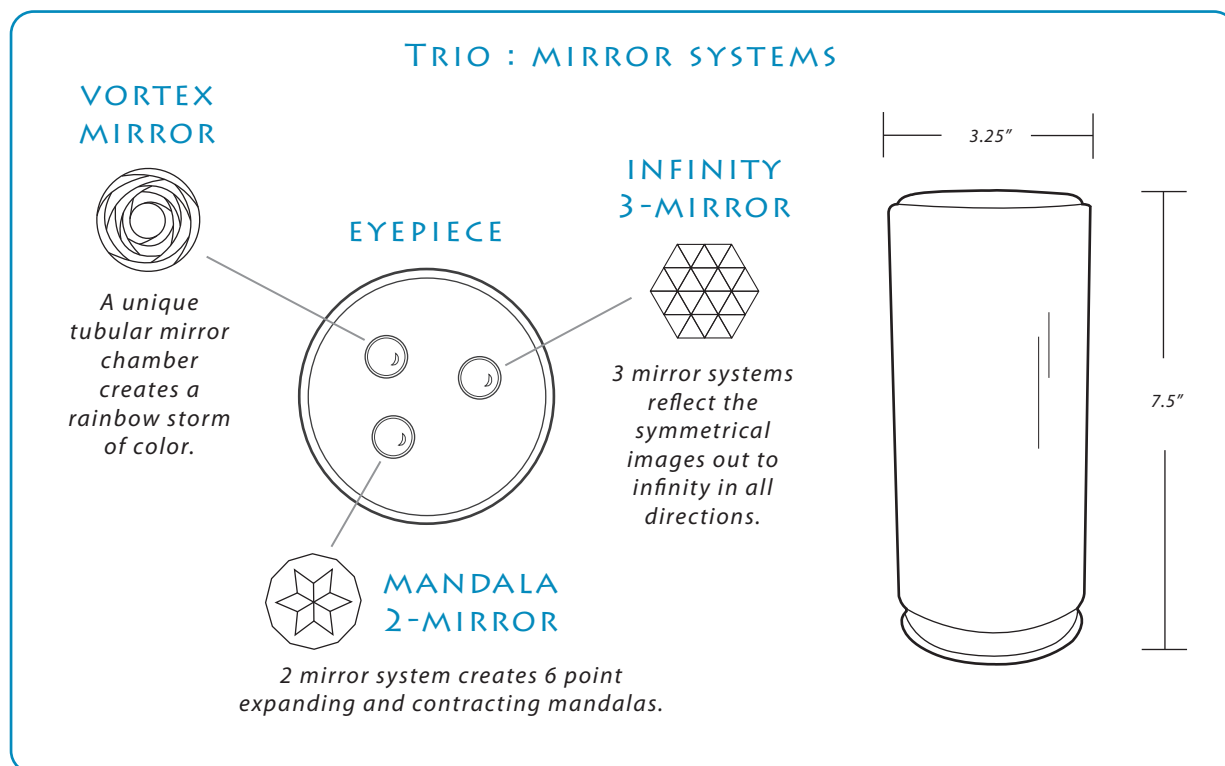

**RESERVOIR:** The oil filled reservoir hold multi-color hand crafted art objects such as polymer clays, seashells, beads & glass. The objects tumble at random so the pattern does not repeat and each viewing is unique.

**OPTIMAL VIEWING:** You simply rotate the entire kaleidoscope to activate the movement of the art objects. Since the art object will pass slowly through the oil and settle at the bottom of the reservoir, it is best for more elaborate patterns to have the viewing port of choice to be located in the bottom position. Or, spin the kaleidoscope a little first, then stop with the viewport in the lower position and let the art object tumble into view. If you keep the viewing port in the top position, the art objects will tumble down and away so only the unique black starry night background will be in view.

**These kaleidoscopes are 'side-lit'** which means bright light enters the object chamber from the side and illuminates the hand crafted art objects. This design technique creates a black background which can deliver more vibrant, crisper patterns when compared to kaleidoscopes that you point directly at the light.

**DISPLAY VIEWING AREAS** with overhead lights, near windows and especially sunlight, or bright lamp sources closely available will enhance viewing experiences.





## KALEIDOSCOPE OVERVIEW COLOR SPIRIT, THEME SPIRIT, MUSIC BOX

**Color Spirit Collection:** These kaleidoscopes celebrate the spirit and inspiration of specific colors. Each individual color has attributes linked to different attitudes and emotions. Every color is unique in its ability to connect with people and effect their mood. Creative inspiration, relaxation and meditation are some ways people connect and experience these color spirits. Our Charcoal and White models are a mixed color pallets showcasing the energy of combining colors inside. We invite you to find the colors that move you most.

**Theme Spirit Collection:** These kaleidoscopes are inspired by nature. They celebrate the classic symmetry occurring in nature through snowflakes, seastars and flower blossoms. The patterns do not repeat so you experience unfolding images that mimic these design gifts from nature. We also have a unique *music box scope* that plays classical music while viewing cloud-like images. Your sense of sight and sound are engaged simultaneously. All these kaleidoscopes are unique one-of-a-kind experiences.

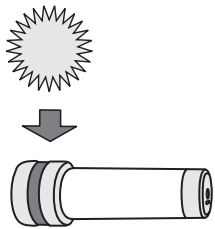

These kaleidoscopes are 'side-lit' which means bright light enters the object chamber from the side to illuminate the hand crafted art objects. This design technique creates a black background which in turn creates more vibrant, crisper mandala patterns when compared to kaleidoscopes that you point directly at the light.

**DISPLAY VIEWING AREAS** with overhead lights, near windows & especially sunlight, or bright lamp sources closely available will enhance the viewing experience.

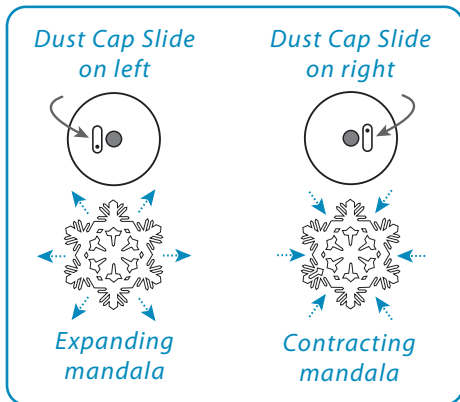
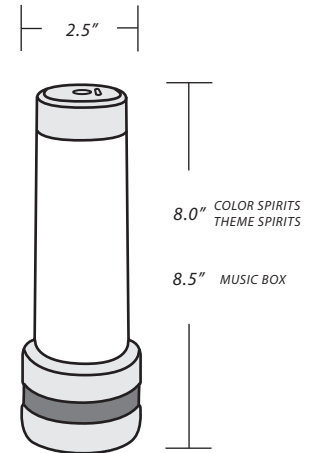

These kaleidoscope models have a unique dust cap lens protector that prevents dust build-up on the eyepiece over time. There is a magnification lens which allows people wearing glasses to remove their glasses and better see inside. **Depending on the orientation of the dust cap slide when in the viewing position, one can enjoy and study expanding or contracting mandala patterns.**

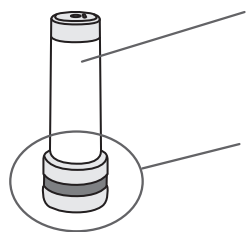

The interior contains optical grade 'front-surface' mirrors. Precision geometry design by hand cutting and assembly of mirror systems are required for making high quality images. **These 2 mirror designs create 6-point mandala patterns.**



The object chamber will rotate independently and contains hand crafted art objects such as polymer clays, glasswork, resins, bead work and other colorful time tested design secrets. **The art objects tumble in mineral oil so the pattern does not repeat and each viewing is unique.** An interactive 'living art' to inspire creativity and calm. The dynamic imagery and beautiful symmetrical patterns are fun for all ages to enjoy!

